

DG01-C0128G Meeting Table

ASSEMBLY INSTRUCTION

Thanks for purchasing one of our products, please read carefully the assembly instructions before the installation (Attention: Do not tighten the screws before all screws are in place).

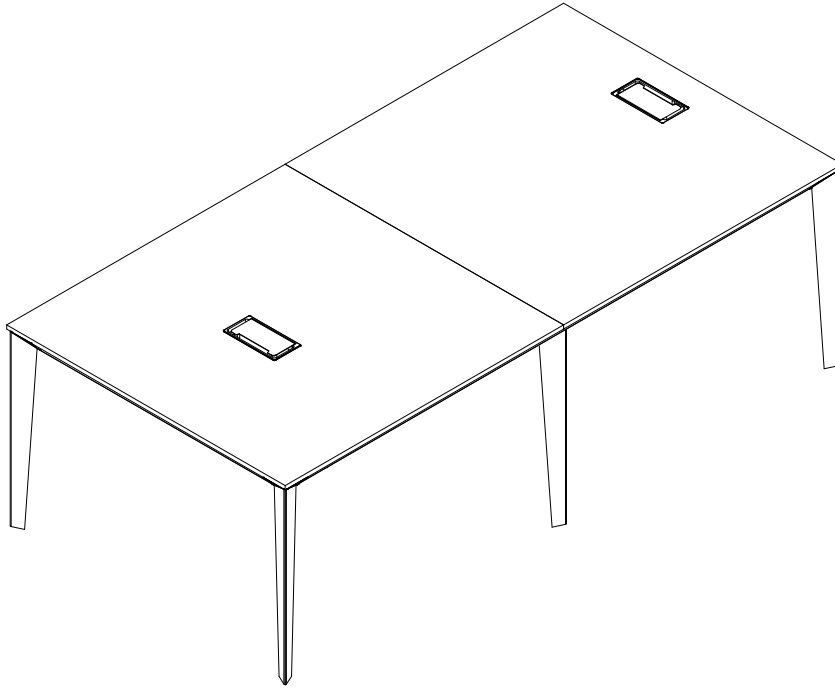

DG01-C0128G Meeting Table	Model No.	Dimension	Carton Qty
	DG01-C0128G	3200W*1400D*750H	4

120 MINS

**2 PERSONS
ASSEMBLY**

General Care:

-Keep your furniture from direct sunlight-Use desk pads and coasters to protect the surface from dents, scratches, and moisture from hot or cold liquids.

Cleaning:

-For cleaning, wipe the surface with a damp (not wet) cloth or with a clean and dry lint.

IMPORTANT - Please Read These Instructions Carefully Before Assembly.

Keep children and animals away from the work area, small parts could cause choking if swallowed.

Assemble the item as close to its intended position (in the same room) as possible.

Assemble on a soft level surface to avoid damage.

Remove all fittings from the plastic bags and separate them into their groups.

Check you have all the components and tools listed. Make sure you have enough space to layout the parts before assembly.

Do not stand or put weight on the product, which could cause damage.

Additional Tool required is screw-driver.



Dispose of all packaging carefully and responsibly.

Parts of the assembly will be easier with 2 people.

Every few months, check that there are no loose fittings on this unit.

This product should not be discarded with household waste. Take to your local authority waste disposal center.

How to use safely

Spilt liquids should be blotted rather than wiped off. This should be done immediately using a soft cloth after a spillage has occurred, then wipe it clean and dry it as stated above. It's important to carry out this procedure to prevent liquids penetrating the surface as this could cause a separation and/or splitting of the surface material.

Furniture tops may be damaged by hot plates, wet cups and objects with sharp or hard surfaces. It is recommended to use place mats.

Furniture should only be used in accordance with its structure and intended purpose of use. For your safety, the furniture should not be used as the replacement of a ladder, steps or hanger, etc.

If some parts are missing or damaged, stop using the furniture until they are replaced with the original replacements.

Doors, drawers, and shelves should not be unnecessarily left open (pulled out) as it can endanger the safety of users, especially children.

The Furniture should be placed at least 1 meter from active heat sources such as radiators and heaters. They should be used in rooms that are dry, closed and protected against the effect of atmospheric conditions including the effect of direct sunlight. Too dry or damp air may cause deformities to some parts of the furniture. Avoid placing the furniture on damp surface.

Stop using them in case of easing (unscrewing) of screws, bolts or nuts.

Please Keep this for Future Reference!

PRODUCT CHECK

Upon receiving the furniture, please check product size, carton quantity.

The DG01-C0128G Meeting Table should be packaged in 4 cartons. The shipping mark to be show on 1 of 4, 2 of 4, 3 of 4 and 4 of 4.

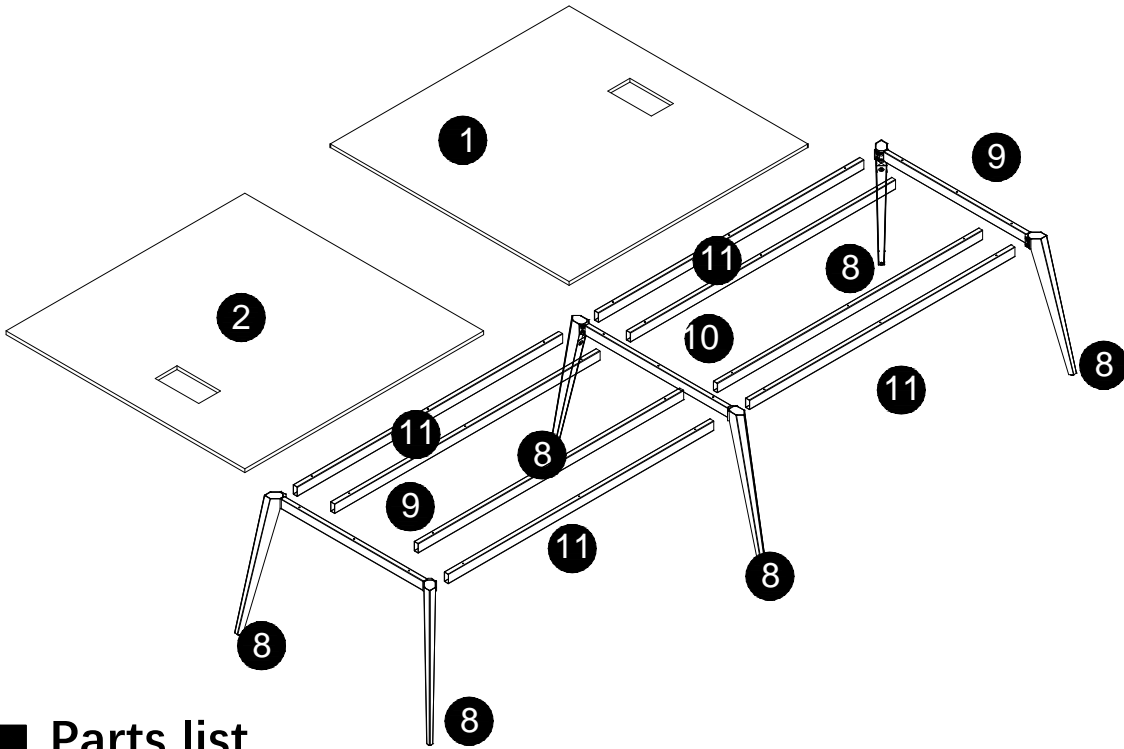

■ Parts list

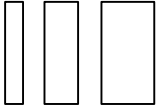

NO.	Dimension	QTY	Drawing
1	1600*1200*16	1	
2	1600*1200*16	1	
3			
4			
5			
6			
7			
8		6	



■ Assembly Steps

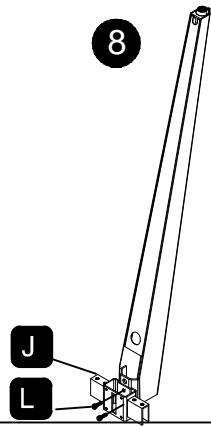



5

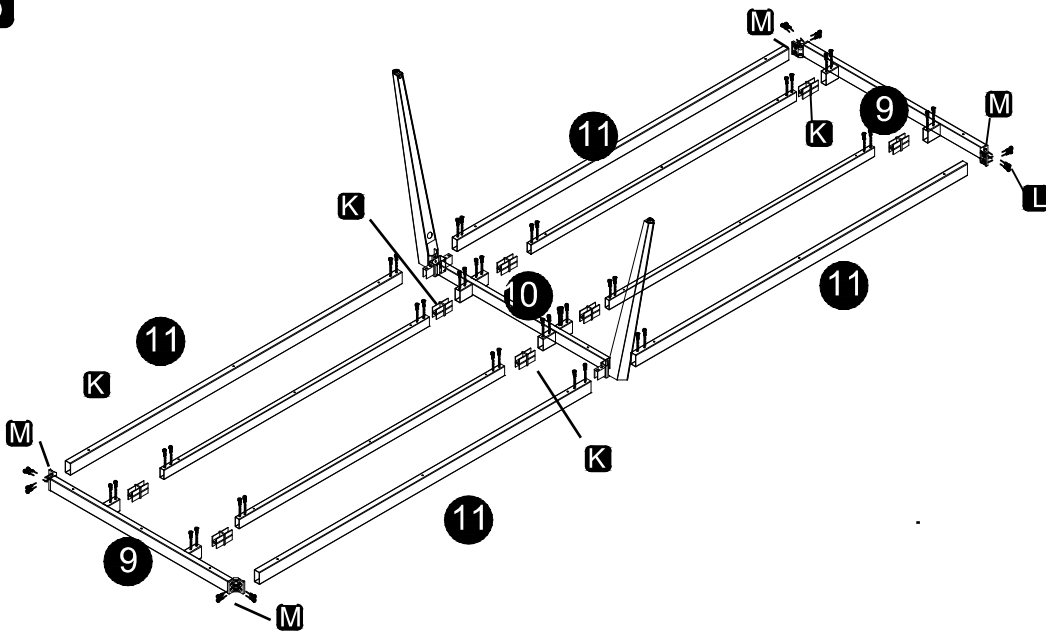

■ SCREWS	
J 	x 2
L 	M6*20
	x 4



6

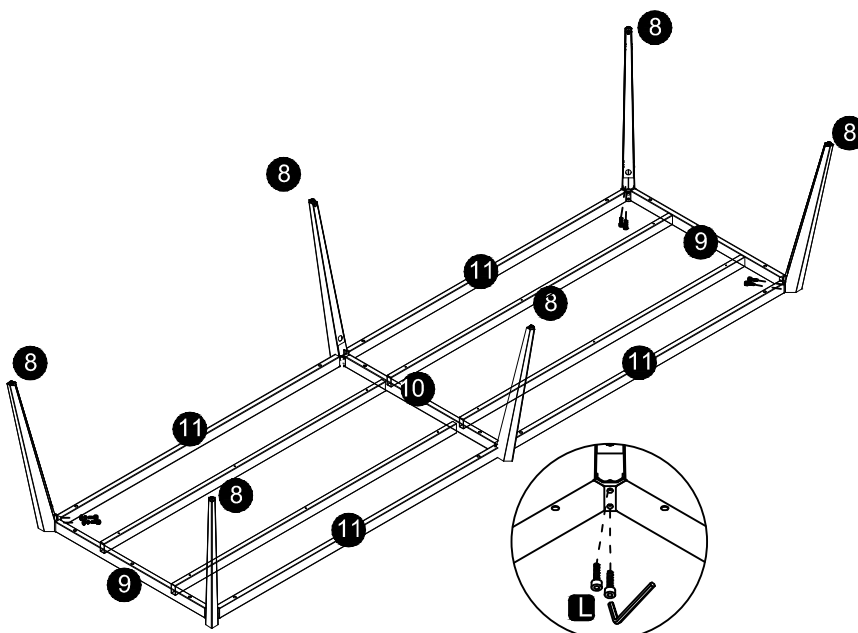

■ SCREWS	
K 	x 8
M 	x 4
L 	M6*20
	x 56

7



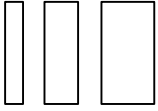

■ SCREWS	
L 	M6*20
	x 8

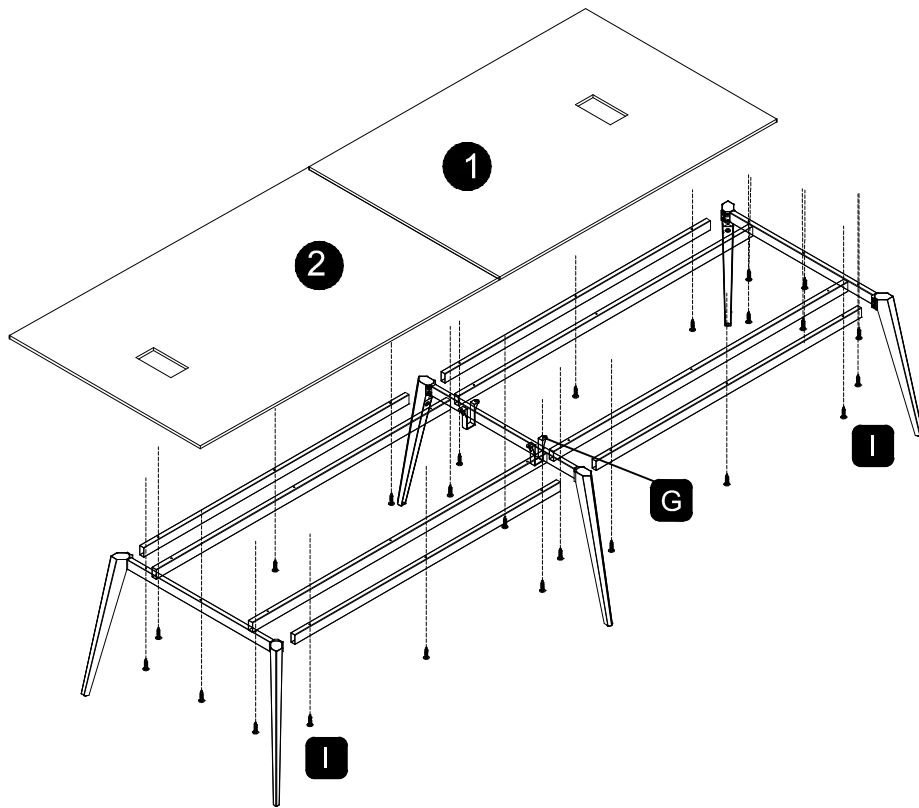

■ Assembly Steps

8



■ SCREWS	
I	M4*16
	x 34
G	
	x 2

9

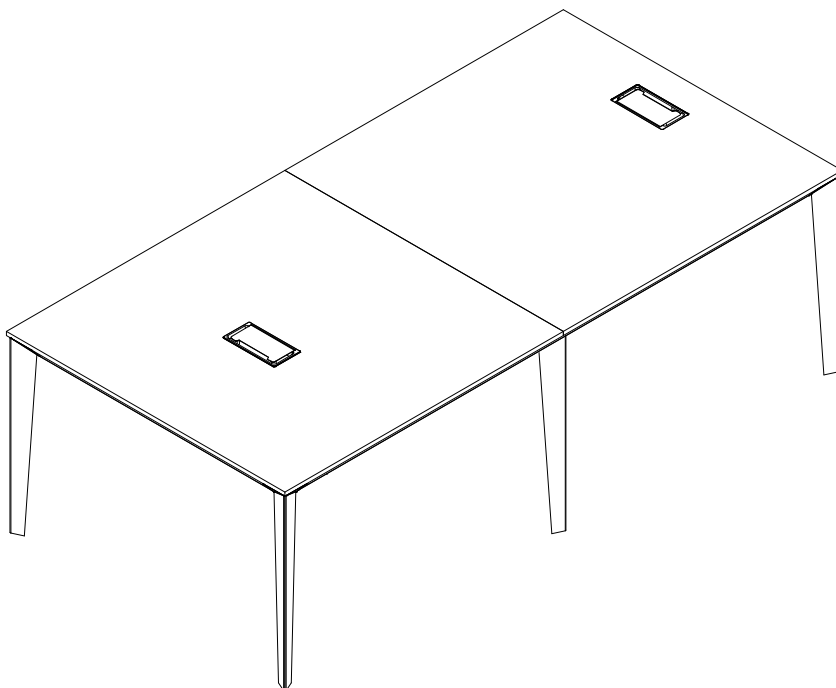

NOTA FINAL:

No arrastre los muebles ya que esto puede dañar las patas. En su lugar, pida al menos a 2 personas que levante con cuidado y precaución desde cualquier extremo.

IMPORTANTE: GUÍA DE CUIDADO DE TUS MUEBLES DE TABLERO DE MELAMINA

Lea información importante sobre sus muebles.

- Quite el polvo frecuentemente con un paño limpio, húmedo y sin pelusa.
- Evite el uso de productos químicos o disolventes al limpiar los muebles.
- No coloque objetos calientes sobre ninguna superficie de mueble.
- Evite exponer sus muebles a la luz solar intensa.
- No esponga sus muebles a ningún líquido.
- No permita que objetos afilados o ásperos raye la superficie de los muebles.
- Al mover muebles, no los arrastre por el suelo.